

REVISIONS			
Rev.	Modification	Date	Done By
D	150 PSIG Steam Rating, Removed Soft Chem Gasket & SS Retainer, Mica shield added	12/10/2018	NPH
E	Steam service removal, NACE note Updated	11/16/2020	NPH

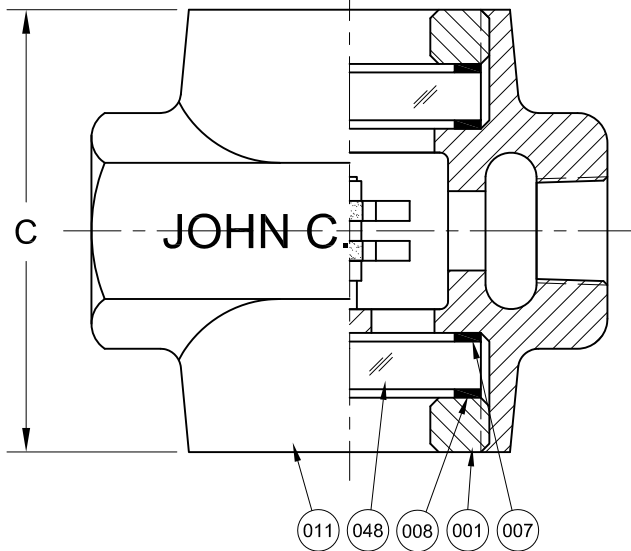
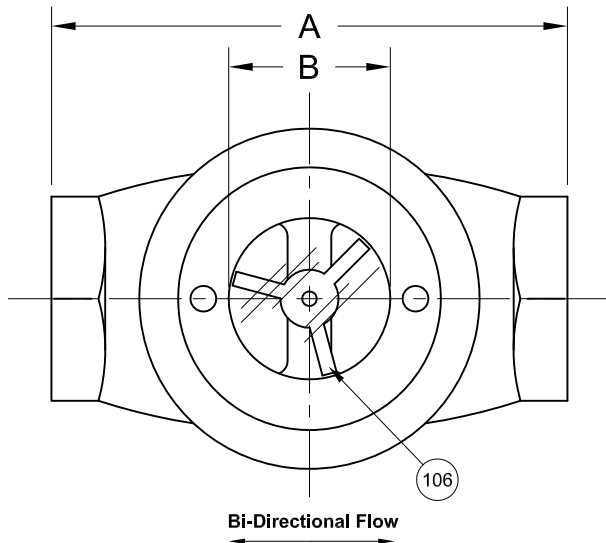

ASME CLASS 150 SERVICE PRESSURE/TEMP. RATINGS			
*Limited to Gasket & Glass Material			
Temp. (°F)	Pressure (PSIG)		
	CS	316SS	Bronze
-20 to 100	285	275	225
150	270	255	225
200	260	235	210
250	245	225	195
300	230	215	180
350	215	205	165
400	200	195	150
450	185	180	N/R
500	170	170	N/R

BILL OF MATERIALS						
* - Denotes an Optional, Non-Standard Material						
No.	Name of Part	Qty.	Material	Max. Temp. (°F)	Material Grade/Notes	
011	Body	1	Carbon Steel		ASTM A216 WCB	
			Bronze		ASTM B62	
			316SS		ASTM A351 CF8M	
007	Gasket	2	Neoprene	250		
			Gylon®	500	Gylon® 3504	
			*EPDM	250		
			*Viton®	400		
			*Graphite	500		
			*Non Asbestos	500		
			*Buna-N	250		
009	Inner Shield	2	Mica V4		(Not Pictured)	
048	Lens	2	Tempered Boro.	500		
106	Rotor Assembly	1	PTFE/316SS	500		
Non-Wet	001	Retainer	2	Brass		
	008	Cushion	2	Non-Asbestos	500	

PRODUCT SPECIFICATIONS										
FNPT Size	A		B		C		Weight		First Rate of Indication GPM	Max Flow Rate GPM
	In.	mm.	In.	mm.	In.	mm.	lbs.	kg.		
1/2	3-3/4	95	1-3/16	30	3-1/4	83	3	1.4	1.2	15.5
3/4	3-3/4	95	1-3/16	30	3-1/4	83	3	1.4	2.2	24.3
1	4-1/4	108	1-7/16	37	3-21/32	93	4	1.8	2.5	38.1
1-1/4	5-1/2	140	2-1/8	54	4-7/8	124	9.2	4.2	4.5	60.7
1-1/2	5-1/2	140	2-1/8	54	4-7/8	124	9.0	4.1	5.8	79.5
2	5-1/2	140	2-1/8	54	4-7/8	124	8.6	3.9	8.1	124.3

KEY NOTES:

- Country of Origin: USA
- Carbon Steel & Stainless Steel Wetted Materials are NACE MR0175 Compliant
- Rotator NOT recommended for Steam Service

S12 Series Configuration Choices:

Reference the Series S12 Model Number Matrix on our Website or Inquire with our Sales Team

Viton® is a Registered Trademark of The Chemours Company
Gylon® is a Registered Trademark of Garkock Sealing Technologies

JOHN C ERNST LLC.		www.johnernst.com	
		21 Gail Ct. Sparta, N.J. USA	
Series S12 Threaded SFI - Rotor - ASME Rated			
Sheet 1 of 1	Drawn By NPH	Tolerances, unless otherwise noted	
Scale: NTS	Approved By GEW	Dec.: ± Frac.: ± Ang.: ±	
Dim.: Var.	Date: 10-DEC-18	Dwg. No.: SC2.00S12.01.0.1	Size: A
			Rev. E