

REVISIONS			
Rev.	Modification	Date	Done By

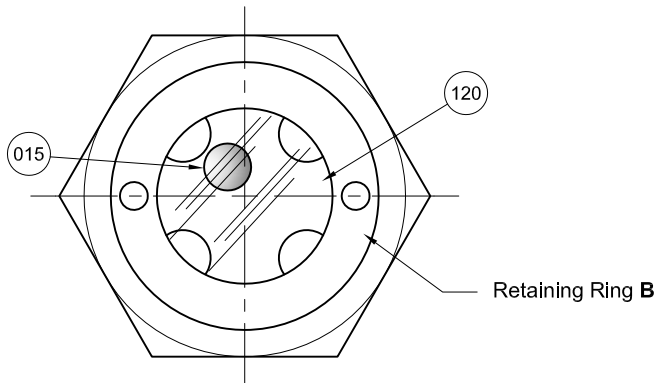

With Optional Reflector & Ball

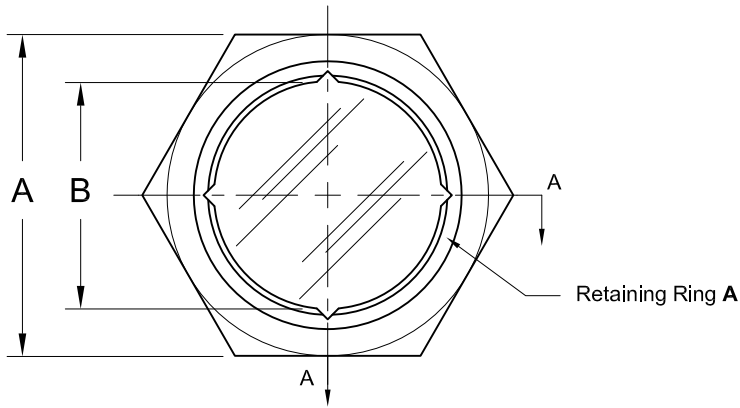
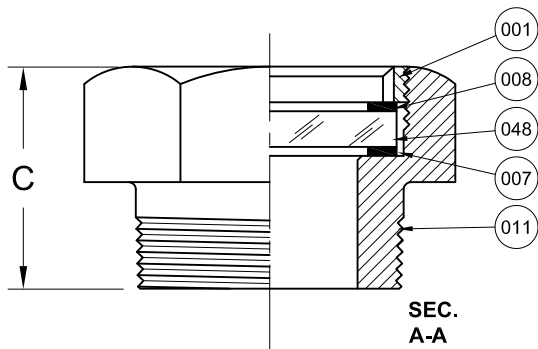

BILL OF MATERIALS					
* - Denotes an Optional, Non-Standard Material					
Item No.	Name of Part	Qty.	Material	Max. Temp. (°F)	Material Grade / Notes
011	Body	1	316SS		
007	Gasket	1	Viton®	400	
			*EPDM	250	
			*Neoprene	250	
			*Graphite	500	
			*Non-Asbestos Fiber	500	
009	(Optional) Inner Shield	1	Mica	500	(Not Shown)
015	(Optional) Indicating Ball	1	3003 Aluminum	300	
			Polypropelene	180	
048	Lens	1	Annealed Boro.	400	
			*Tempered Boro.	500	
120	(Optional) Reflector ₂	1	316SS		
001	Retainer	1	Brass		CDA 360
			*303SS		Sizes 3/4", 1" & 2" Only
008	Cushion	1	Non-Asbestos	500	

PRODUCT SPECIFICATIONS											
MNPT Size	A		B		C		Retainer Type	Pressure Rating (PSIG) ₁			Weight
	In.	mm.	In.	mm.	In.	mm.		Annealed @ 400°F	Tempered @ 200°F	Tempered @ 500°F	
	1/2	1	25.4	19/32	15.1	1		25.4	A	250	
3/4	1-1/8	28.6	11/16	17.5	1-1/8	28.6	A	250	350	150	3 oz.
1	1-3/8	34.9	15/16	23.8	1-1/4	31.8	A	200	300	150	4 oz.
1-1/4	1-7/8	47.6	1-1/4	31.8	1-15/32	37.3	A	150	250	150	7 oz.
1-1/2	2-1/4	57.2	1-1/2	38.1	1-15/32	37.3	A	100	200	150	14 oz.
2	2-1/2	63.5	1-17/32	38.9	1-1/2	38.1	B	100	200	150	1.4 lbs.
3 ₂	3-1/2	88.9	2-7/32	56.4	1-19/32	40.5	B	150	250	150	2.2 lbs.

KEY NOTES:

1. Ratings are Limited to **Gasket & Glass Material**
2. Reflector Not Available on 3" Unit

W16 Series Configuration Choices:

Reference the Series W16 Model Number Matrix on our Website or Inquire with our Sales Team

Viton® is a Registered Trademark of the Chemours Company

JOHN C ERNST LLC.		www.johnernst.com 21 Gail Ct. Sparta, N.J. USA	
Series W16 316 Male Threaded Sight Plug			
Sheet 1 of 1	Drawn By WAS	Tolerances, unless otherwise noted Decimal: Fraction: ±1/64" Angle:	
Scale: NTS	Approved By JCW		
Dim.: Var.	Date: 03-MAY-18	Dwg. No.: SC2.00W16.03.0.0	Rev. --