

REVISIONS			
Rev.	Modification	Date	Done By
B	Updated note	12/16/2020	NPH
C	Added Bracket Info	3/14/2022	NPH

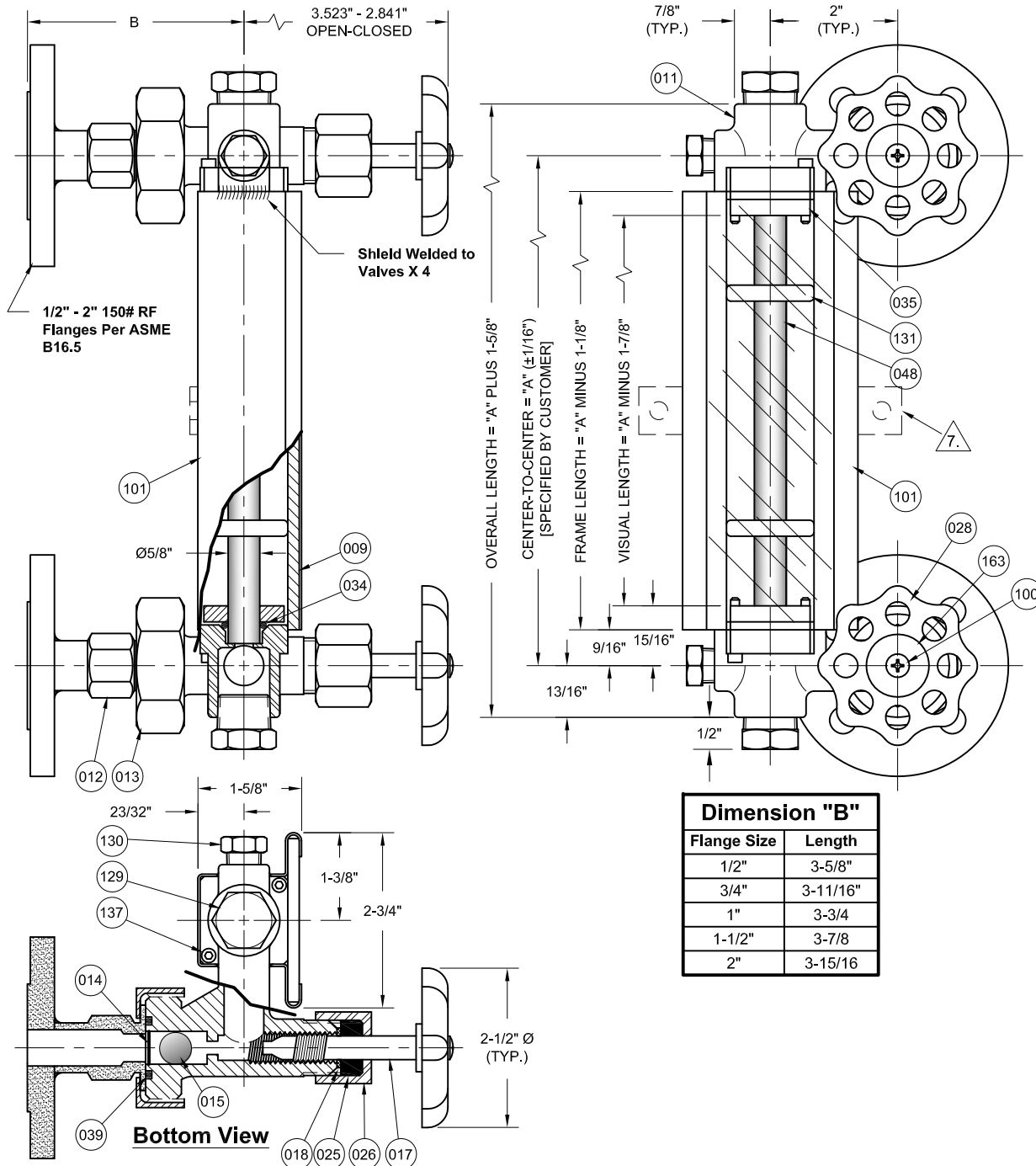

BILL OF MATERIALS CHOOSE ONE

No.	Name of Part	Qty.	Material
011	Wetted Valve Body		Zinc Pl. Steel OR 316SS
012	Tail Pipe / Flange	2	Zinc Pl. Steel OR 316SS
014	Ball Check Retainer	2	15-7SS
015	Ball Check	2	316SS
017	Stem	2	316SS
018	Stem Packing Retainer	2	316SS
025	Stem Packing	2	PTFE
034	Sight Tube O-Ring	2	Viton® / FEP Encapsulated Silicone /
039	Union O-ring	2	Buna-N / EPDM
048	Sight Glass/Tube	Var.	Borosilicate / FEP / PVC / Lexan®
129	1/2" Top/Bottom Plug	2	Zinc Pl. Steel OR 316SS
130	1/4" Side Plug	2	Zinc Pl. Steel OR 316SS
009	Shield	1	Lexan® (Inquire for Scale Printing)
013	Union Nut	2	Zinc Pl. Steel OR 304SS
026	Stem Packing Nut	2	Zinc Pl. Steel OR 303SS
028	Handwheel	2	Cast Zinc
035	Retaining Plates	2	316SS
100	Handwheel Screw	2	18-8SS
101	3 Sided Frame		Zinc Pl. Steel OR 304SS
131	Bumper Ring	Var.	Buna-N
137	Studs	4	18-8SS
163	Name Plate	1	Aluminum

Notes:

- Rated for **FULL** vacuum service
- Addition of Splicers reduces visibility ~1" per splicer
- Each Floating Union Tailpipe (012), allows for ±1/4" variance for misaligned process connection centerlines
- Due to Glass Seating, gauge cannot be flipped for desired orientation. Please Inquire for orientation requirements
- Nameplate is on lower valve
- Bracket(s) are Included when Frame Lengths exceed 96" & are centered on the back of the frame.
- Bracket Dimensions are 1/8" Thick x 3/4" Wide x 4-1/8" Long, with 2 9/32" Holes on 3-1/2" Centers.

Dimension "B"	
Flange Size	Length
1/2"	3-5/8"
3/4"	3-11/16"
1"	3-3/4"
1-1/2"	3-7/8"
2"	3-15/16"

J14A Series Configuration Choices:
Reference the Series J14A Model Number Matrix on our Website or Inquire with our Sales Team

Lexan® is a Registered Trademark of General Electric, Co. USA
Viton® is a Registered Trademark of The Chemours Company

JOHN C ERNST LLC.		www.johnernst.com	
		21 Gail Ct. Sparta, N.J. USA	
Series J14A Shielded Level Gauge w/ Valves - 5/8" OD Glass 1/2" - 2" Flanged 150# Connections			
Sheet: 1 of 1	Drawn By: WAS	Tolerances, unless otherwise noted Dec.: ± Frac.: ± Ang.: ±	Size: A
Scale: NTS	Approved By: JCW		
Dim.: Inches	Date: 12-APR-17	Dwg. No.: SC2.0J14A.01.0.0	Rev.: C