

REVISIONS			
Rev.	Modification	Date	Done By

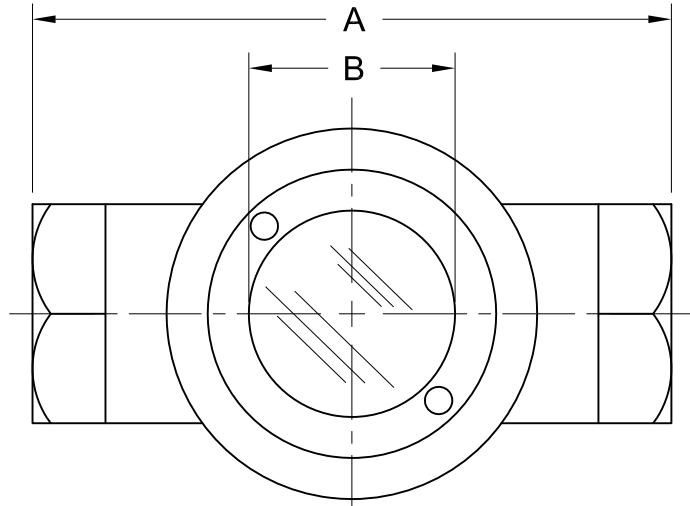

Bi-Directional

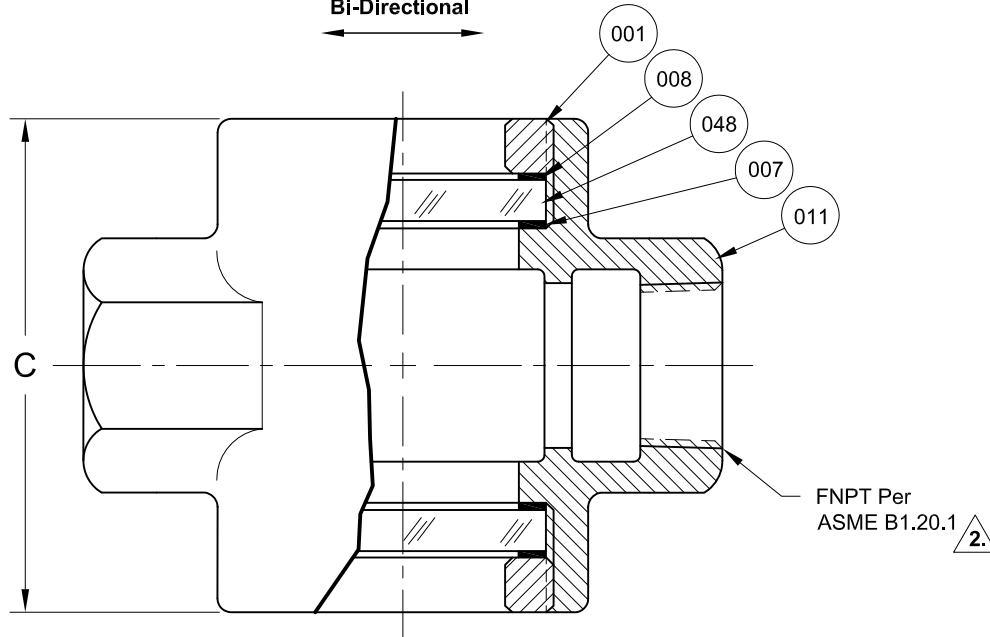

BILL OF MATERIALS
* - Denotes an Optional, Non-Standard Material

No.	Name of Part	Qty.	Material	Max. Temp. (°F)	Material Grade/Notes
011	Body	1	Carbon Steel		ASTM A-216 WCB
			Bronze		ASTM B62
			316SS		ASTM A-351 CF8M
007	Gasket	2	Neoprene	250	
			Gylon®	500	Gylon® 3545
			*EPDM	250	
			*Viton®	350	
			*Graphite	500	
			*Non Asbestos Fiber	500	
			*Buna-N	250	
048	Lens	2	Annealed Borosilicate	450	
			*Tempered Borosilicate	500	
008	Cushion	2	Non-Asbestos	500	
001	Retainer	2	Brass		ASTM B16
			*316LSS		ASTM A479
163	Nameplate	1	SS		Affixed to Unit (Not Pictured)

Notes:

- Only Carbon Steel & 316SS Bodies Conform to NACE MR0175 for Wetted NACE Service
- Female Socket Weld Connections Available (Per ASME B16.11)**

PRODUCT SPECIFICATIONS

FNPT Size ₂	A		B		C		Weight	
	In.	mm.	In.	mm.	In.	mm.	lbs.	kg.
1/4 & 3/8	3	76	13/16	21	2	51	1-1/2	0.7
1/2 & 3/4	3-3/4	95	1-1/4	32	2-3/4	70	3	1.4
1	4-1/4	108	1-1/4	32	3-1/2	89	4	1.8
1-1/4 & 1-1/2	5-1/2	140	2	51	4-3/4	121	9	4.1
2	6-1/4	159	2	51	5	127	11	5.0

Rating: 150 PSIG @ 450°F with Appropriate Gaskets
(Bronze Body 400°F Max.)

S12B Series Configuration Choices:

Reference the Series S12B Model Number Matrix on our Website or Inquire with our Sales Team

Viton® is a Registered Trademark of The Chemours Company
Gylon® is a Registered Trademark of Garkock Sealing Technologies

JOHN C ERNST LLC.

www.JOHNERNST.com
21 Gail Ct. Sparta, N.J. USA

Series S12B Threaded Plain Sight Flow Indicator

Sheet: 1 of 1	Drawn By: WAS	Tolerances, unless otherwise noted Dec.: ± Frac.: ± Ang.: ±	Size: A
Scale: NTS	Approved By: JCW		
Dim.: Var.	Date: 31-MAR-17	Dwg. No.: SC2.0S12B.00.0.0	Rev.: --