

REVISIONS			
Rev.	Modification	Date	Done By

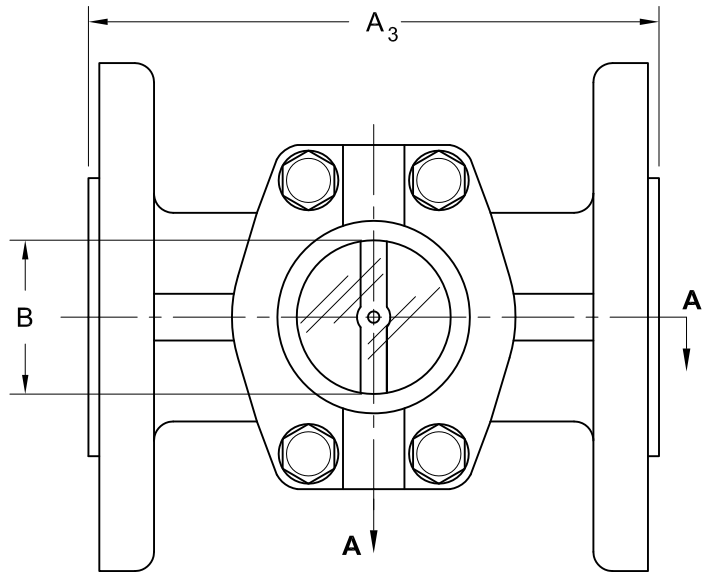

Bi-Directional Flow

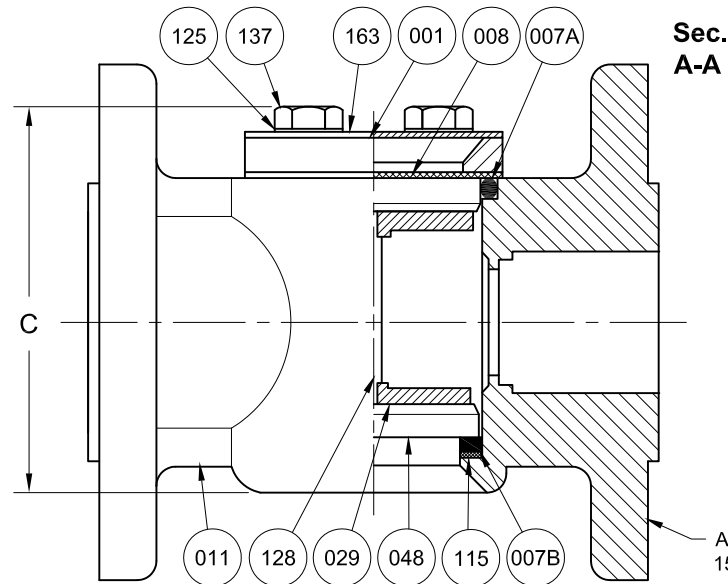

Sec. A-A

ASME CL. 150 Service Press./Temp. Ratings <sub>2</sub>		
Temp. (°F)	Pressure (PSIG)	
	CS	316SS
-20 to 100	285	275
150	270	255
200	260	235
250	245	225
300	230	215
350	215	205
400	200	195

\*Consult Sales for Alt. Ratings

ASME B16.5  
150# RF

BILL OF MATERIALS					
* - Denotes an Optional, Non-Standard Material					
No.	Name of Part	Qty.	Material	Max. Temp. (°F)	Material Grade/Notes
011	Body	1	Carbon Steel		ASTM A216-WCB
			316SS		ASTM A351-CF8M
007A	Gasket	2	Viton®	400	
007B			*Neoprene	250	
			*EPDM	250	
			*PTFE	400	
			*Kalrez®	400	
	*Buna-N	212			
029	Bridge	2	316LSS		
048	Lens	2	Tempered Borosilicate		
128	Pin	1	316SS		
001	Retainer	1	Plated Steel		
008	Cushion	1	Non-Asbestos Fiber		
009	Outer Shield (Opt.)	1	Polycarbonate	200	(Not Pictured)
115	Spacer	1	PTFE	400	
125	Washers	4	Plated Steel		
137	Studs	4	Plated Steel		
163	Nameplate	1	Aluminum		

PRODUCT SPECIFICATIONS									
Flange Size	A		B		C		Weight		Vacuum <sub>1</sub>
	In.	mm.	In.	mm.	In.	mm.	lbs.	kg.	
1-1/2	6-1/2	165.1	2	50.8	4-1/2	114.3	11.1	5.03	-12.6
2	7	177.8	2	50.8	4-1/2	114.3	14.9	6.76	-12.6
2 <sub>3</sub>	7-7/8	200.0	2	50.8	4-1/2	114.3	15.2	6.89	-12.6

Notes:

1. Vacuum Service Rating: 85.5% of Full Vacuum / 25.6" of Hg. / 2.1 PSIA
2. Limited to Glass, Gasket, & Indicator Ratings
3. Request Extended OAL Unit for 7-7/8" OAL

**S13F Series Configuration Choices:**

Reference the Series S13F Model Number Matrix on our Website or Inquire with our Sales Team

Kalrez® is a Registered Trademark of E.I. DuPont de Nemours Co. Inc.  
Viton® is a Registered Trademark of the Chemours Company

JOHN C ERNST LLC.		www.johnernst.com 21 Gall Ct. Sparta, N.J. USA	
Series S13F High Pressure Plain SFIs 1-1/2" - 2" Flanged			
Sheet: 1 of 1	Drawn By: WAS	Tolerances, unless otherwise noted Dec.: ±    Frac.: ±    Ang.: ±	Size: A
Scale: NTS	Approved By: JCW		
Dim.: Var.	Date: 09-JAN-17	Dwg. No.: SC2.0S13F.00.1.1	Rev.: --