

REVISIONS			
Rev.	Modification	Date	Done By

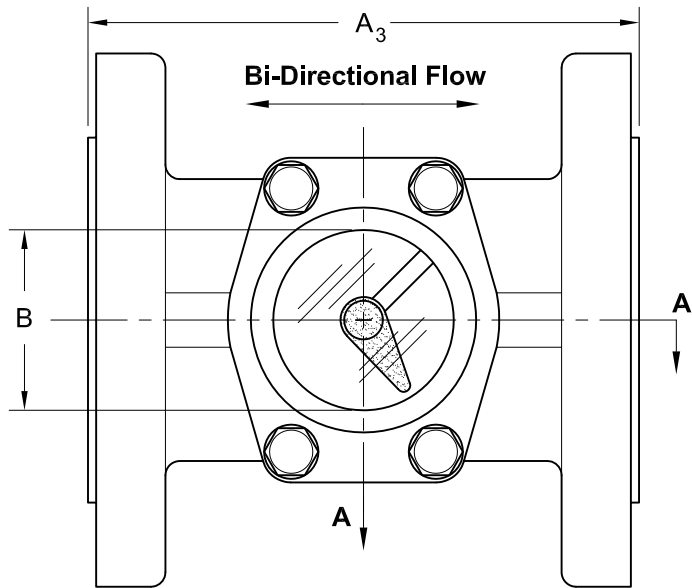

ASME CL. 150 Service Press./Temp. Ratings 2		
Temp. (°F)	Pressure (PSIG)	
	CS	316SS
-20 to 100	285	275
150	270	255
200	260	235
250	245	225
300	230	215
350	215	205
400	200	195
*Consult Sales for Alt. Ratings		

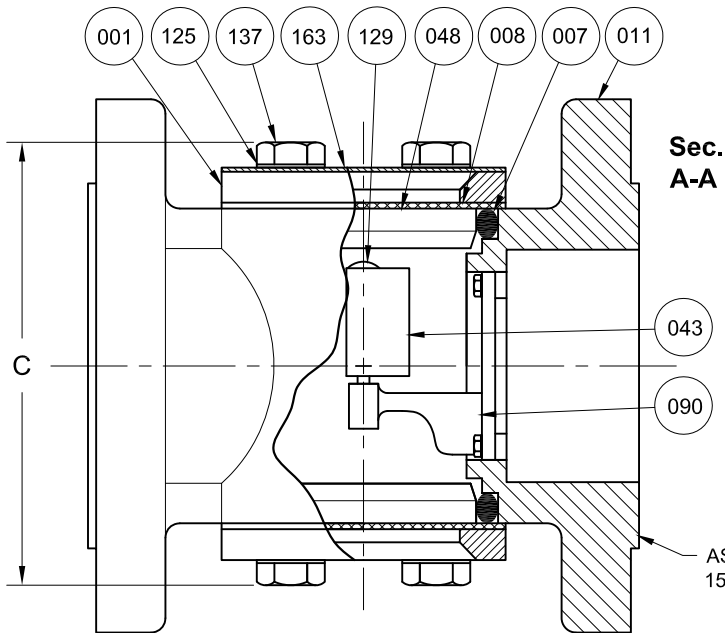

BILL OF MATERIALS						
* - Denotes an Optional, Non-Standard Material						
No.	Name of Part	Qty.	Material	Max. Temp. (°F)	Material Grade/Notes	
011	Body	1	Carbon Steel		ASTM A216-WCB	
			316LSS		ASTM A351-CF8M	
007	Gasket	2	Viton®	400		
			*Neoprene	250		
			*EPDM	250		
			*PTFE	400		
			*Kalrez®	400		
			*Buna-N	212		
043	Flapper	1	Ryton®	400	Brown	
048	Lens	2	Tempered Borosilicate			
090	Cap	1	PTFE	400		
129	Rotor Arm/Studs	1	316SS			
Non-Wetted	001	Retainer	2	Plated Steel		
	008	Cushion	2	Non-Asbestos Fiber		
	009	Outer Shield (Opt.)	1	*Polycarbonate	200	(Not Pictured)
	125	Washers	4	Plated Steel		
	137	Studs	8	Plated Steel		
163	Nameplate	1	Aluminum			

PRODUCT SPECIFICATIONS									
Flange Size	A		B		C		Weight		Vacuum 1
	In.	mm.	In.	mm.	In.	mm.	lbs.	kg.	PSIG
3	8	203.2	3	76.2	7-5/8	193.7	32.1	14.56	-12.6
3 3	9-3/8	238.1	3	76.2	7-5/8	193.7	31.8	14.42	-12.6
4	9	228.6	3	76.2	7-5/8	193.7	43.9	19.91	-12.6
4 3	11	279.4	3	76.2	7-5/8	193.7	44.2	20.05	-12.6

Notes:

1. Vacuum Service Rating: 85.5% of Full Vacuum / 25.6" of Hg. / 2.1 PSIA
2. Limited to Glass, Gasket, & Indicator Ratings
3. Request Extended OAL Unit for 9-3/8" or 11" Length

S13F Series Configuration Choices:

Reference the Series S13F Model Number Matrix on our Website or Inquire with our Sales Team

Kalrez® is a Registered Trademark of E.I. DuPont de Nemours Co. Inc.
 Ryton® is a Registered Trademark of Solvay Specialty Polymers
 Viton® is a Registered Trademark of the Chemours Company

JOHN C ERNST LLC.		www.johnernst.com 21 Gail Ct. Sparta, N.J. USA	
Sheet: 1 of 1	Drawn By: WAS	Tolerances, unless otherwise noted Dec.: ± Frac.: ± Ang.: ±	
Scale: NTS	Approved By: JCW	Size: A	
Dim.: Var.	Date: 17-JAN-17	Dwg. No.: SC2.0S13F.04.2.0	Rev.: --