

BODY STYLE: 3/4"

BODY STYLE: 1"

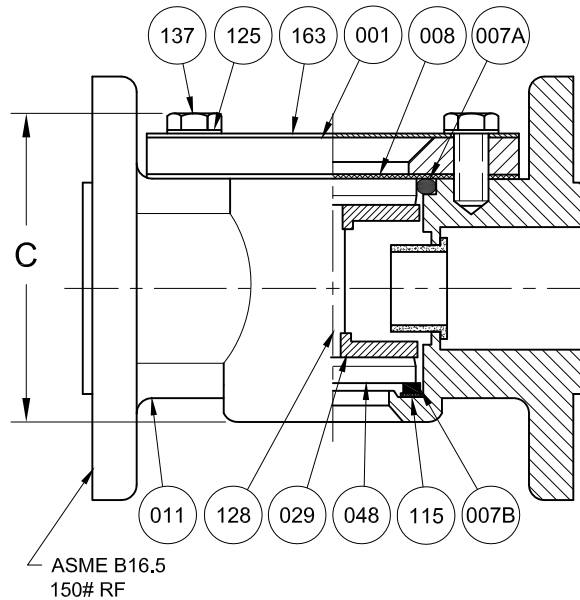
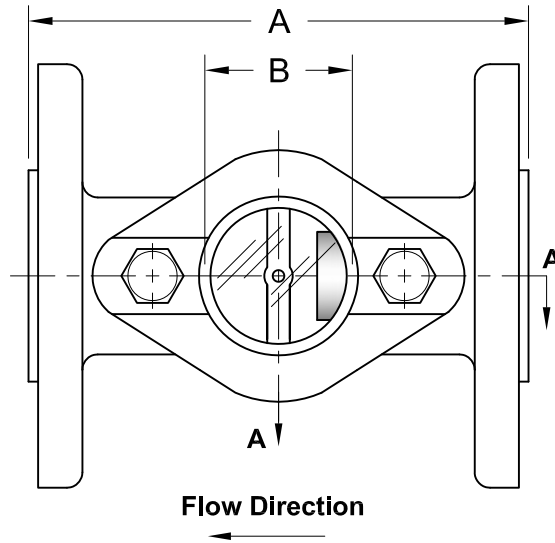
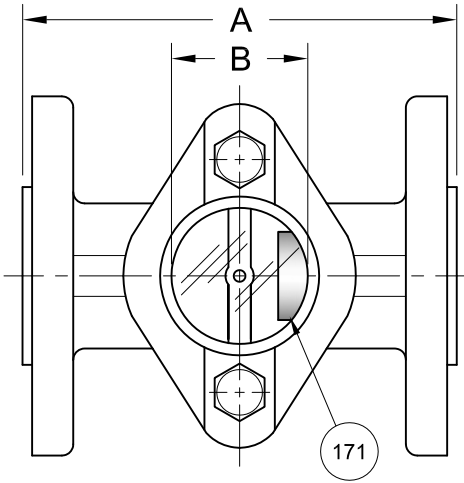

Sec. A-A

ASME CL. 150 Service Press./Temp. Ratings ₂		
Temp. (°F)	Pressure (PSIG)	
	CS	316SS
-20 to 100	285	275
150	270	255
200	260	235
250	245	225
300	230	215
350	215	205
400	200	195

*Consult Sales for Alt. Ratings

REVISIONS			
Rev.	Modification	Date	Done By

BILL OF MATERIALS						
* - Denotes an Optional, Non-Standard Material						
No.	Name of Part	Qty.	Material	Max. Temp. (°F)	Material Grade/Notes	
011	Body	1	Carbon Steel		ASTM A216-WCB	
			316SS		ASTM A351-CF8M	
007A 007B	Gasket	2	Viton®	400		
			*Neoprene	250		
			*EPDM	250		
			*PTFE	400		
			*Kalrez®	400		
	*Buna-N	212				
029	Bridge	2	316LSS			
048	Lens	2	Tempered Borosilicate			
128	Pin	1	316SS			
171	Drip Tube	1	PTFE	400		
Non-Wetted	001	Retainer	1	Plated Steel		
	008	Cushion	1	Non-Asbestos Fiber		
	009	Outer Shield (Opt.)	1	Polycarbonate	200	(Not Pictured)
	115	Spacer	1	PTFE	400	
	125	Washers	2	Plated Steel		
	137	Studs	2	Plated Steel		
163	Nameplate	1	Aluminum			

PRODUCT SPECIFICATIONS									
Flange Size	A		B		C		Weight		Vacuum ₁
	In.	mm.	In.	mm.	In.	mm.	lbs.	kg.	PSIG
3/4	4-5/8	117.5	1-1/2	38.1	3-3/8	85.7	5.8	2.63	-12.6
1	5	127.0	1-1/2	38.1	3-1/2	88.9	6.4	2.90	-12.6

- Notes:**
- Vacuum Service Rating: 85.5% of Full Vacuum / 25.6" of Hg. / 2.1 PSIA
 - Limited to Glass, Gasket, & Indicator Ratings

S13F Series Configuration Choices:
Reference the Series S13F Model Number Matrix on our Website or Inquire with our Sales Team

Kalrez® is a Registered Trademark of E.I. DuPont de Nemours Co. Inc.
Viton® is a Registered Trademark of the Chemours Company

JOHN C ERNST LLC.		www.johnernst.com 21 Gail Ct. Sparta, N.J. USA	
Series S13F Drip Tube High Pressure SFIs - 3/4" - 1" Flanged			
Sheet: 1 of 1	Drawn By: WAS	Tolerances, unless otherwise noted Dec.: ± Frac.: ±1/64" Ang.: ±	Size: A
Scale: NTS	Approved By: JCW		
Dim.: Var.	Date: 14-DEC-16	Dwg. No.: SC2.0S13F.06.0.1	Rev.: --