

REVISIONS			
Rev.	Modification	Date	Done By

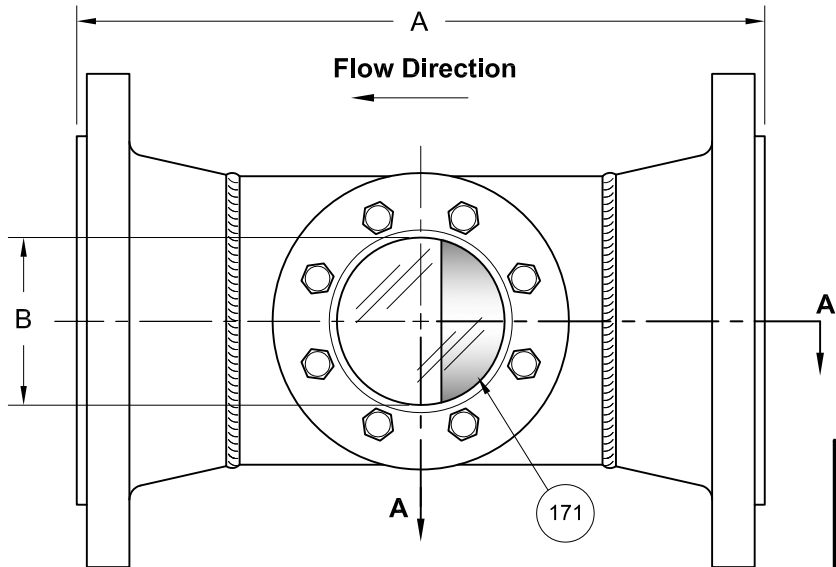

Temp. (°F)	Pressure (PSIG)	
	CS	316SS
-20 to 100	275	275
150	255	255
200	235	235
250	225	225
300	215	215
350	205	205
400	200	195

*Consult Sales for Alt. Ratings

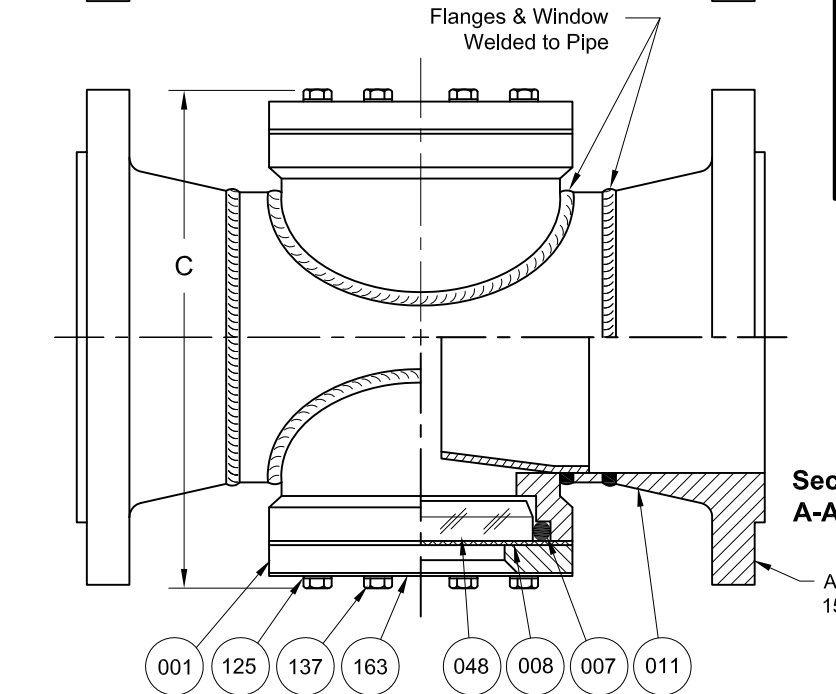

No.	Name of Part	Qty.	Material	Max. Temp. (°F)	Material Grade/Notes	
011	Body	1	Carbon Steel		ASTM A53/A106 (Pipe), ASTM A105 (Flanges)	
			316LSS		ASTM A351	
007	Gasket	2	Viton®	400		
			*Neoprene	250		
			*EPDM	250		
			*PTFE	400		
			*Kalrez®	400		
			*Buna-N	212		
048	Lens	2	Tempered Boro.			
171	Drip Tube	1	PTFE	400		
Non-Wetted	001	Retainer	2	Plated Steel		
	008	Cushion	2	Non-Asbestos Fiber		
	009	Outer Shield (Opt.)	2	Polycarbonate	200	(Not Pictured)
	125	Washers	16	Plated Steel		
	137	Studs	16	Plated Steel		
163	Nameplate	1	Aluminum			

Flange Size	A		B		C		Weight		Vacuum ₁
	In.	mm.	In.	mm.	In.	mm.	lbs.	kg.	PSIG
6	14-1/2	368.3	4	101.6	13-13/16	350.8	85	38.6	-12.6
8	16-1/8	409.6	4	101.6	15-3/16	385.8	125	56.7	-12.6
10	16-1/8	409.6	4	101.6	17-1/16	433.4	165	74.8	-12.6
12	17-1/8	435.0	4	101.6	19-5/16	490.5	250	113.4	-12.6
14	18-1/2	469.9	4	101.6	20-9/16	522.3	315	142.9	-12.6

- Notes:**
- Vacuum Service Rating: 85.5% of Full Vacuum / 25.6 In. of Hg. / 2.1 PSIA
 - Limited to Glass, Gasket, & Indicator Ratings

S13F Series Configuration Choices:

Reference the Series S13F Model Number Matrix on our Website or Inquire with our Sales Team

Kalrez® is a Registered Trademark of E.I. DuPont de Nemours Co. Inc.
 Viton® is a Registered Trademark of the Chemours Company

JOHN C ERNST LLC.		www.johnernst.com 21 Gail Ct. Sparta, N.J. USA	
Series S13F High Pressure Drip Tube Sight Flow Indicators 6" - 14" Flanges			
Sheet: 1 of 1	Drawn By: WAS	Tolerances, unless otherwise noted Dec.: ± Frac.: ± Ang.: ±	
Scale: NTS	Approved By: JCW	Size: A	
Dim.: Var.	Date: 07-JUL-17	Dwg. No.: SC2.0S13F.06.3.1	Rev.: --