

REVISIONS			
Rev.	Modification	Date	Done By
A	Materials updated	12/15/2020	NPH

**BODY STYLE:**  
1/4", 3/8", 1/2", 3/4", 1"

**BODY STYLE:**  
1-1/4", 1-1/2", 2"

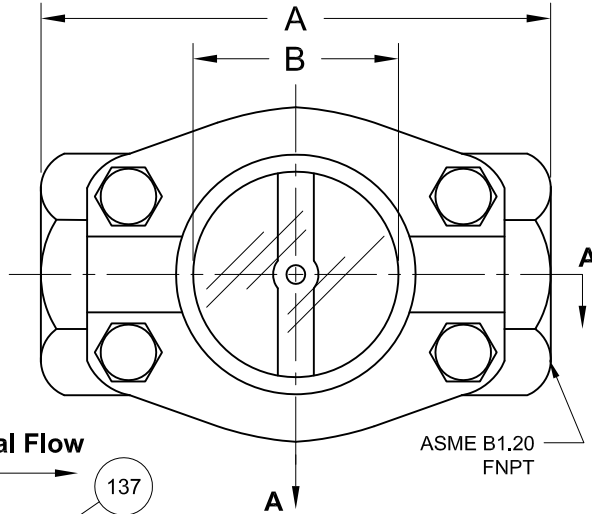
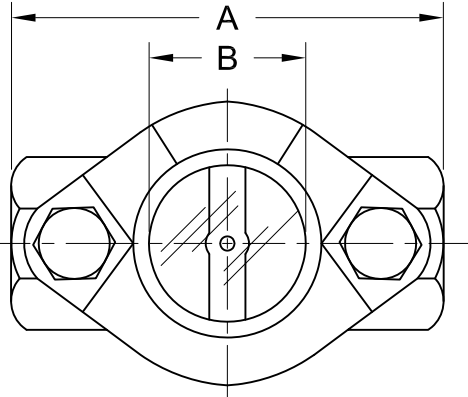

**Bi-Directional Flow**

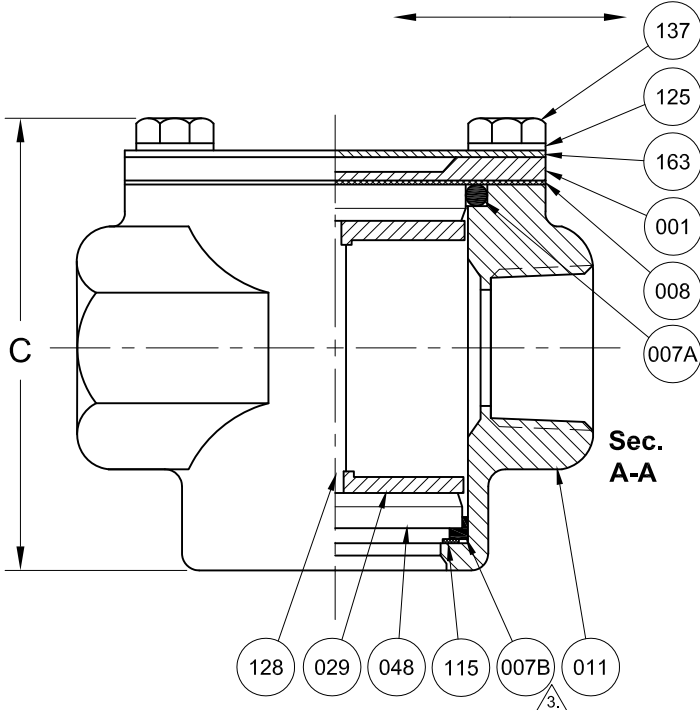

RATINGS <sup>2</sup>	
Temp. (°F)	Pressure (PSIG)
-20 to 150	200
200	165
225	150
250	135
300	100
350	70
400	35

**\*Consult Sales for Alt. Ratings**

BILL OF MATERIALS					
* - Denotes an Optional, Non-Standard Material					
No.	Name of Part	Qty.	Material	Max. Temp. (°F)	Material Grade/Notes
011	Body	1	Carbon Steel		ASTM A216-WCB
			Bronze		ASTM B62-83600
			316SS		ASTM A351-CF8M
007A 007B	Gasket	2	Neoprene	250	
			Viton®	400	
			*EPDM	250	
			*PTFE	400	
			*Kalrez®	400	
	*Buna-N	212			
029	Bridge	2	316LSS		
048	Lens	2	Tempered Soda Lime		
128	Pin	1	316SS		
001	Retainer	1	Plated Steel		
008	Cushion	1	Non-Asbestos Fiber		
009	Outer Shield (Opt.)	1	Polycarbonate	200	(Not Pictured)
115	Spacer	1	PTFE	400	
125	Washers	Var.	Plated Steel		
137	Studs	Var.	Plated Steel		
163	Nameplate	1	Aluminum		

PRODUCT SPECIFICATIONS												
FNPT Size	A CS/SS UNITS		A BRZ./IRN. UNITS		B		C		Weight		# of Studs	Vacuum <sub>1</sub> (PSIG)
	In.	mm.	In.	mm.	In.	mm.	In.	mm.	lbs.	kg.		
1/4	3-5/8	92.1	3-1/4	82.6	1-1/8	28.6	2-3/8	60.3	1.6	0.73	2	-12.6
3/8	3-5/8	92.1	3-1/4	82.6	1-1/8	28.6	2-3/8	60.3	1.6	0.73	2	-12.6
1/2	3-5/8	92.1	3-1/4	82.6	1-1/8	28.6	2-3/8	60.3	1.4	0.64	2	-12.6
3/4	4-1/4	108.0	4-1/4	108.0	1-1/2	38.1	3-1/4	82.6	3	1.36	2	-12.6
1	4-1/4	108.0	4-1/4	108.0	1-1/2	38.1	3-1/4	82.6	2.7	1.22	2	-12.6
1-1/4	5-5/8	142.9	5-1/4	133.4	2	50.8	4-5/16	109.5	8.4	3.81	4	-12.6
1-1/2	5-5/8	142.9	5-1/4	133.4	2	50.8	4-5/16	109.5	7.9	3.58	4	-12.6
2	5-5/8	142.9	5-1/2	139.7	2	50.8	4-5/16	109.5	6.6	2.99	4	-12.6

**Notes:**

1. Vacuum Service Rating: 85.5% of Full Vacuum / 25.6" of Hg. / 2.1 PSIA
2. Limited to Glass & Gasket Ratings
3. Actual Gasket Shape May Vary Based on Material and Size

**S13T Series Configuration Choices:**

Reference the Series S13T Model Number Matrix on our Website or Inquire with our Sales Team

Kalrez® is a Registered Trademark of E.I. DuPont de Nemours Co. Inc., Viton® is a Registered Trademark of the Chemours Company

<b>JOHN C ERNST LLC.</b>		www.JOHNERNST.com 21 Gail Ct. Sparta, N.J. USA	
Series S13T Plain SFIs 1/4" - 2" NPT			
Sheet: 1 of 1	Drawn By: WAS	Tolerances, unless otherwise noted Dec.: ± Frac.: ±1/64" Ang.: ±	Size: A
Scale: NTS	Approved By: JCW		
Dim.: Var.	Date: 24-MAY-16	Dwg. No.: SC2.0S13T.00.0.0	Rev.: A