

REVISIONS			
Rev.	Modification	Date	Done By

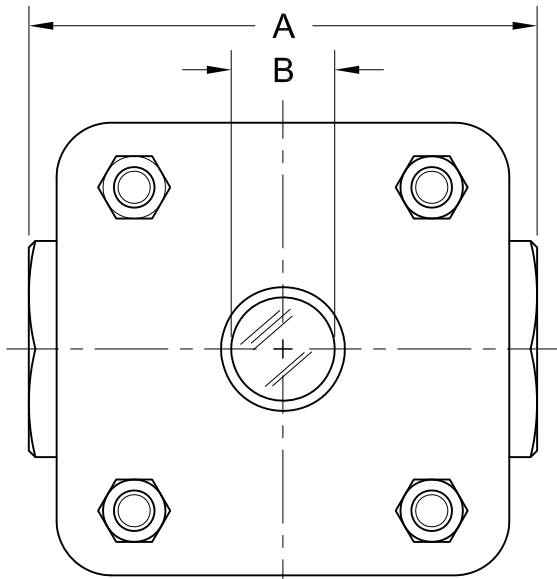

**ASME CLASS 300 SERVICE PRESSURE/TEMP. RATINGS**

\*Limited to Gasket & Glass Material

Temp. (°F)	Pressure (PSIG)	
	CS	316SS
-20 to 100	740	720
150	705	670
200	675	620
250	665	590
300	655	560
350	645	535
400	635	515
450	615	495
500	600	480

\*Consult Sales for Higher & Lower Temps.

**BILL OF MATERIALS**  
\* - Denotes an Optional, Non-Standard Material

No.	Name of Part	Qty.	Material	Max. Temp. (°F)	Material Grade / Notes
011	Body	1	Painted Carbon Steel		ASTM A216-WCB
			316SS		ASTM A351-CF8M
007	Gasket	2	Neoprene	250	
			Gylon®	500	Gylon® 3545
			*Viton®	350	
			*Graphite	500	
			*Non Asbestos	500	IFG-5500
048	Lens	2	Tempered Boro.	500	
001	Retainer	2	Electro-Galvanized Zinc Plated Carbon Steel		ASTM A216-WCB or ASTM A516 GR.70
			*316SS		
			Yellow Zinc Plated Steel		ASTM A194-2H
			*316SS		
004	Nut	4			
008	Cushion	2	Non-Asbestos	500	IFG-5500
137	Stud	4	Yellow Zinc Plated Steel		ASTM A354-BD
			*316SS		
163	Name Plate	1	SS		

Bi-Directional Flow

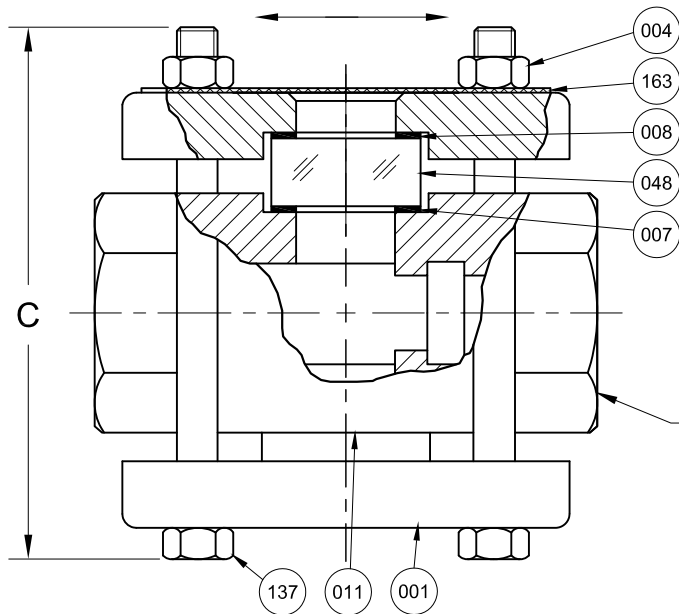

Female NPT Per ASME B1.20.1

**PRODUCT SPECIFICATIONS**

FNPT Size	A		B		C <sub>1</sub>		Weight	
	In.	mm.	In.	mm.	In.	mm.	lbs.	kg.
1/4	3	76	27/32	21	3-1/4	83	6.0	2.7
3/8	3	76	27/32	21	3-1/4	83	6.0	2.7
1/2	3-3/4	95	1-1/16	27	4-1/4	108	8.4	3.8
3/4	3-3/4	95	1-1/16	27	4-1/4	108	8.4	3.8
1	4-1/4	108	1-3/8	35	4-3/4	121	9.6	4.4
1-1/4	5-1/2	140	2	51	7-1/4	184	15.6	7.1
1-1/2	5-1/2	140	2	51	7-1/4	184	15.6	7.1
2	6-1/4	159	2	51	7-1/4	184	15.6	7.1

**KEY NOTES:**

- Standard Bolt Length Shown in "C" Dimension (±1/8")
- Dual Window & Fused Glass Options Available by Request
- In Accordance with NACE MR-01-75 & ISO15156-1 for Wetted Materials

**S16TB Series Configuration Choices:**

Reference the Series S16TB Model Number Matrix on our Website or Inquire with our Sales Team

Gylon® is a Registered Trademark of Garlock Sealing Technologies  
Viton® is a Registered Trademark of the Chemours Company

**JOHN C ERNST LLC.**

www.johnernst.com  
21 Gail Ct. Sparta, N.J. USA

Series S16TB Class 300# Female Threaded Plain SFI - Type B

Sheet: 1 of 1	Drawn By: WAS	Tolerances, unless otherwise noted Dec.: ±    Frac.: ±    Ang.: ±	Size: A
Scale: NTS	Approved By: GEW		
Dim.: Var.	Date: 05-MAR-18	Dwg. No.: SC2.S16TB.00.0.0	Rev.: -