

REVISIONS			
Rev.	Modification	Date	Done By
0	Original	6/28/2016	WAS
A	Added Minimum Indicator Flow Rate	10/3/2018	WAS

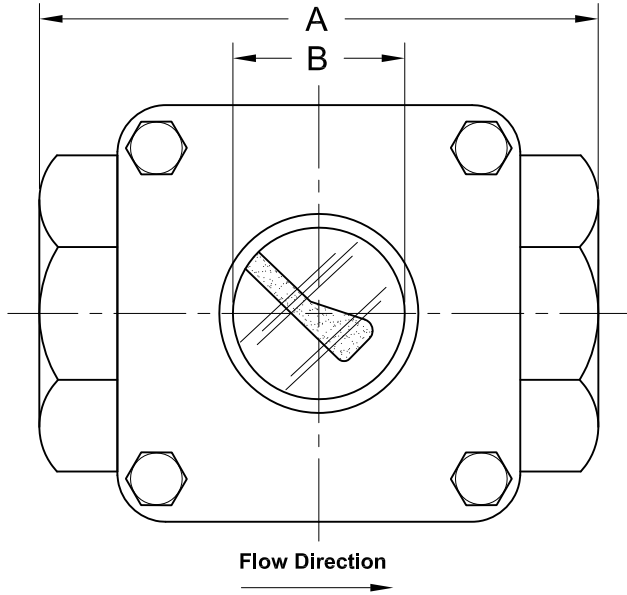

**ASME CLASS 300 SERVICE
PRESSURE/TEMP. RATINGS**
*Limited to Gasket & Glass Material

Temp. (°F)	Pressure (PSIG)	
	CS	316SS
-20 to 100	740	720
150	710	670
200	680	620
250	665	590
300	655	560
350	645	535
400	635	515
450	620	495
500	605	480

*Consult Sales for Higher & Lower Temps.

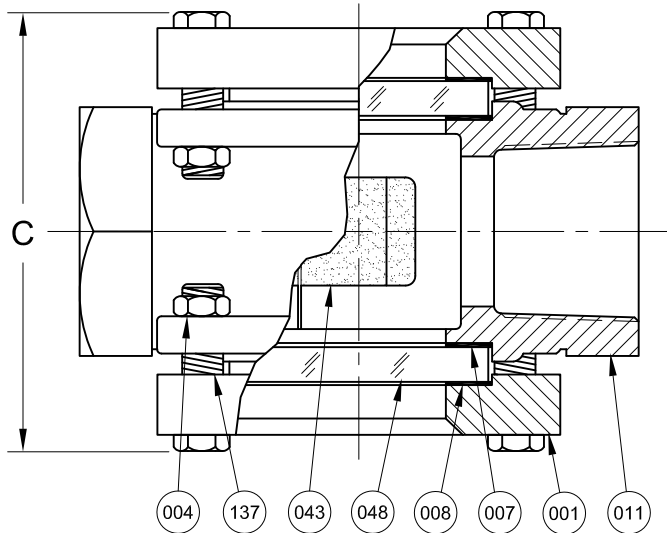

BILL OF MATERIALS
* - Denotes an Optional, Non-Standard Material

No.	Name of Part	Qty.	Material	Max. Temp. (°F)	Material Grade
011	Body	1	Carbon Steel		ASTM A-216 WCB
			316SS		ASTM A-351 CF8M
			Neoprene	250	
007	Gasket	2	Gylon®	500	Gylon® 3504
			*EPDM	250	
			*Viton®	350	
			*Graphite	500	
			*Non Asbestos	500	Klinger C-4400
			*Buna-N	250	
048	Lens	2	Tempered Boro.	500	
043	Flapper Assembly	1	316SS		
008	Cushion	2	Non-Asbestos	500	Klinger C-4400
001	Retainer 1	2	Carbon Steel		ASTM A-216 WCB
			316SS		ASTM A-351 CF8M
137	Stud	8	Plated Steel		SAE Gr. 5
			*316SS		ASTM A193-B8M
004	Nut	8	Plated Steel		SAE Gr. 5
			*316SS		ASTM A194-8M

KEY NOTES:

1. Retainers are the Same Material as the Body
2. For NACE Compliance, Please Inquire

PRODUCT SPECIFICATIONS

FNPT Size	A		B		C		Weight		1st Rate of Indication
	In.	mm.	In.	mm.	In.	mm.	lbs.	kg.	GPM
1/2	3-3/4	95	1-1/4	32	4	102	7	3.2	1.0
3/4	3-3/4	95	1-1/4	32	4	102	7	3.2	1.9
1	4-1/4	108	1-1/4	32	4-1/2	114	13	5.9	2.3
1-1/2	5-1/2	140	1-3/4	44	5-7/8	149	14	6.4	5.8
2	6-1/4	159	2	51	6-3/8	162	20	9.1	8.1

S16TC Series Configuration Choices:

Reference the Series S16TC Model Number Matrix on our Website or Inquire with our Sales Team

Gylon® is a Registered Trademark of Garlock Sealing Technologies
Viton® is a Registered Trademark of the Chemours Company

JOHN C ERNST LLC.

www.johnernst.com

21 Gail Ct. Sparta, N.J. USA

Series S16TC Sight Flow Indicator - Flapper 300# Threaded

Sheet 1 of 1	Drawn By WAS	Tolerances, unless otherwise noted Dec.: ± Frac.: ± Ang.: ±	Size: A
Scale: NTS	Approved By: JCW		Date: 03-OCT-18
			Rev.: A