

JOHN C. ERNST LLC.
21 Gail Ct, Sparta, NJ. 07871

Doc. No.: SIM.00W11.001

Replaces: E31024

Date: 20-OCT-21

Created By: NPH

Approved By: JCW

Rev: --

JOHN C.
ERNST LLC
PROCESS OBSERVATION SOLUTIONS
SIGHT WINDOWS

INSTALLATION, OPERATION & MAINTENANCE MANUAL
FOR SERIES: **W11**

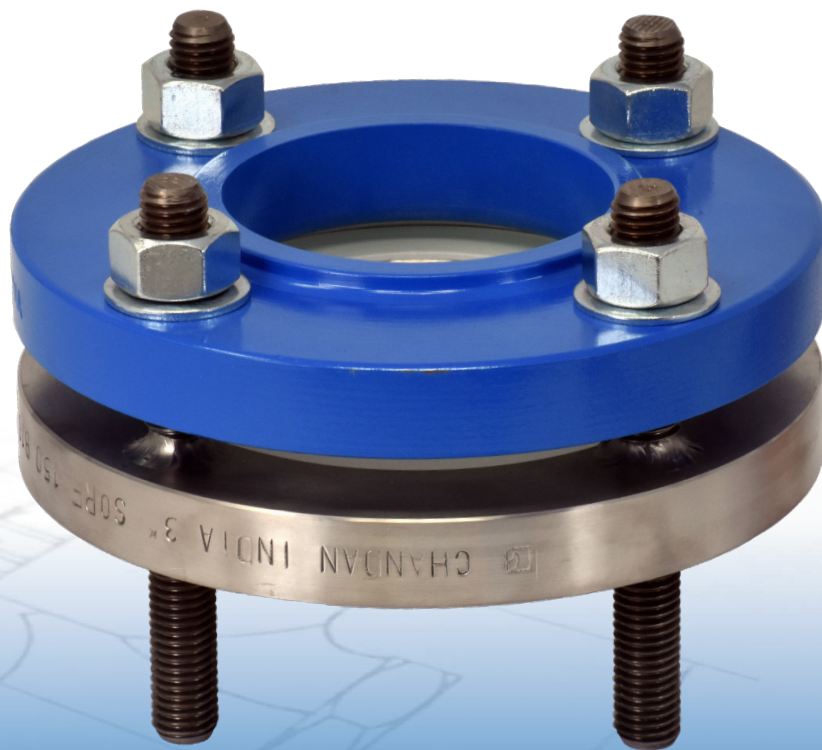

JOHNERNST.COM

Tel.: 888-943-5000 - Fax: 973-940-1620 - sales@johnernst.com

TABLE OF CONTENTS

I. INTRODUCTION	1
II. INSPECTION	1
RECEIVING INSPECTION	
END USER'S RATING INSPECTION	
III. INSTALLATION	2
GENERAL PRECAUTIONS	
PLACEMENT GUIDELINES	
WELDING PREPARATION	
IV. OPERATION	3
PRE-OPERATIONAL CHECK	
OPERATING	
V. MAINTENANCE	4
GENERAL MAINTENANCE PROCEDURES	
DISASSEMBLY	
REASSEMBLY	
VI. SPARE PARTS INDEX	5
TROUBLESHOOTING	
LIMITED WARRANTY	7
GENERAL PRESERVATION	7

PRODUCT QUICK SPECS.

Connection	Size	Pressure Group	Material	Standard Gasket	Ratings
Flat Weld Pad	1" - 8"	HP	Carbon Steel	Neoprene	285 PSIG @ -20°F to 100°F 245 PSIG @ 250°F
	6" & 8"	STD	Carbon Steel	Neoprene	150 PSIG @ -20°F to 250°F
	1" - 8"	HP	316L SS	Soft Chem PTFE	275 PSIG @ -20°F to 100°F 195 PSIG @ 400°F
	6" & 8"	STD	316L SS	Soft Chem PTFE	150 PSIG @ -20°F to 250°F
Bolt-On	1" - 8"	HP	Carbon Steel	Neoprene	285 PSIG @ -20°F to 100°F 245 PSIG @ 250°F
	6" & 8"	STD	Carbon Steel	Neoprene	150 PSIG @ -20°F to 250°F
	1" - 8"	HP	316L SS	Soft Chem PTFE	275 PSIG @ -20°F to 100°F 195 PSIG @ 400°F
	6" & 8"	STD	316L SS	Soft Chem PTFE	150 PSIG @ -20°F to 250°F
Weld Neck	1" - 8"	HP	Carbon Steel	Neoprene	285 PSIG @ -20°F to 100°F 245 PSIG @ 250°F
	6" & 8"	STD	Carbon Steel	Neoprene	150 PSIG @ -20°F to 250°F
	1" - 8"	HP	316L SS	Soft Chem PTFE	275 PSIG @ -20°F to 100°F 195 PSIG @ 400°F
	6" & 8"	STD	316L SS	Soft Chem PTFE	150 PSIG @ -20°F to 250°F

Limited to Glass & Gasket Ratings

I. INTRODUCTION

NOTICE

John C. Ernst does not have any control over the manner in which this sight window is handled, installed or used. John C. Ernst cannot and will not guarantee that this sight window is suitable or compatible for the user's specific application.

This manual has been prepared as a guide for personnel responsible for installation and maintenance of these items. All instructions must be read and understood thoroughly before attempting any installation, operation and maintenance.

John C. Ernst Sight Windows are designed for either observation of flow in a processed line, or to observe level in a tank or vessel. They are available in a variety of sizes and connection types. With the appropriate connection type, these Sight Windows can be utilized for:

- Illumination
- Media Flow Observation
- Media Clarity Monitoring
- Air/Bubble Presence Detection

These Sight Windows consist of 4 primary components. The materials of each component will vary based on the characteristics of the application(s). If additional information on the materials is needed, or contact the John C. Ernst Sales Department.

- **Base Chamber:** This provides a rigid attachment to your tank, vessel or process line by either welding or bolting into place. This part has a flat, grooved, machined cavity in which the cover flange compresses critical components into.
- **Gaskets:** These will tightly seal between the glass and the base flange or act as a cushion between the glass and cover flange.
- **Glass Discs:** These are installed between the base and cover flanges to provide the window for observation into the tank, vessel or process line. A glass cushion (typically a fiber material) is laid on the other side to prevent the cover flange from damaging the glass surface.
- **Cover Flange:** This flange retains the above components by bolting over the other components. Depending on the connection style, these may be pre-torqued to the base flange.

WARNING

Exceeding the design ratings or application's data limits can cause the glass to break, the unit to leak, or sudden release of pressure. Failure to keep operations below design ratings may result in serious personal injury.

II. INSPECTION

Receiving Inspection

Upon receipt of the sight window, check all components carefully to ensure that damage did not occur. If damage is evident or suspected, do not attempt installation.

On larger sizes, the glass may be shipped separately to prevent damage during transit.

End User's Rating Inspection

Prior to installation the user(s) must confirm that:

1. The user's purchase order, and the John C. Ernst Technical Drawing, all agree with the actual operating conditions at the installation site.
2. The connections and inside of the unit are clean and free of any foreign material.
3. The materials of construction are chemically compatible with both the media(s) and unit's surrounding environment.

WARNINGS

Failure to follow instructions could result in a malfunction or breakage of the indicator, resulting in fluid escaping from the unit and fragmenting glass.

Always wear safety glasses when installing, servicing or operating sight flow indicators.

Failure to follow precautions can result in personal injury.

CAUTION

Prior to installation, the information on the nameplate should be compared with the proposed service conditions of the system. Should any discrepancies be noted, immediately contact the factory advice.

 **WARNING:** Cancer and Reproductive Harm - www.P65Warnings.ca.gov

III. INSTALLATION

⚠ WARNING

Only qualified experienced personnel who are familiar with this equipment and thoroughly understand the implications of the tables and all the instructions should assemble the equipment. Failure to read and comply with the following instructions could result in personal injury.

General Precautions

Do NOT proceed with installation of sight windows unless:

- The glass has been examined and is free of scratches and other imperfections. Glass that has been chipped or scratched is weakened and may break under pressure, thus should not be used under any circumstances. Unit's ratings are no longer valid for glass that is weakened.
- The connections and sealing surfaces have been cleaned, and are free of foreign materials.

Placement Guidelines

Locate the sight window:

- Where it is easily seen.
- Away from areas where objects will be dropped, thrown, or generally allowed to make contact with the viewing window.
- So that it is protected from dust, grit, tools, or other objects which might scratch, chip or break the viewing window glass.
- So it is protected from external thermal shock – e.g., if a high temperature application would be exposed to a cold air blast or cold water wash.

⚠ WARNING

Failure to locate the sight window as stated in the above list can cause serious injuries to personnel.

Welding Preparation

For units that are to be welded, a secure work surface is required to lay parts out as they are removed.

Disassembly - Welding

1. While holding sight window firmly, loosen and remove nuts and bolts as required.
2. Remove cover, cushions, glass shield (if any), and gaskets and set aside.

⚠ WARNING

Extreme care must be taken to avoid damage to the cushions, glass, shields(if any) and gaskets. If any are damaged in any way their use can result in a sudden release of contained media causing serious injury to personnel.

Note: In this instance; glass, cushions, shields (if any) and gaskets can be reused as the sight window has yet to be torqued at assembly.

Reassembly - Welding with Steel Spacer

- Place the steel spacer on the chamber in place of the glass, carefully as not to gouge or scar the glass seating surfaces.
- Install cover into place over the spacer.
- Install bolts and nuts as required, hand tight.

NOTICE

John C. Ernst recommends that all welded sight windows be welded in place with a steel spacer to prevent warping.

Welding

NOTICE

Welding must adhere to all applicable local and national codes also any recognized safety practices.

Flat/Radius Pad or Weld Neck Sight Windows

1. Tank or vessel must be relieved of all pressure or vacuum, allowed to reach ambient temperature and must be drained or purged of all fluids prior to welding.
2. A hole must be cut in the tank or vessel at the location that the user wants the window to be installed. The hole must be equal in size or larger than the vision diameter of the chamber.
3. Center chamber assembly over the hole.
4. Hold chamber assembly in place and tack weld in 4 places 90° apart.
5. Complete welding of the chamber to tank or vessel by making continuous pass around the entire circumference of the chamber.

Socket-weld Sight Windows

1. Place socket-weld connection of the sight window over the connection pipe until the pipe bottoms out inside the sight window.
2. Back the sight window out so that there is a 1/16" gap between the end of the pipe and the bottom surface of the socket weld connection of the sight window.
3. Hold chamber assembly in place and tack weld in 2 places 180° apart.
4. Complete the welding of the chamber to the pipe by making a continuous pass around the entire circumference of the pipe.

After Welding

1. Ensure the unit has cooled to ambient temperature before disassembling.
2. Remove bolts, nuts cover and steel spacer as required.
3. Check flatness of each glass seating surface and under the cover for distortion by using a known flat piece of glass of the same size, and a thickness gauge. Surfaces must be flat within a 0.005" tolerance.

Continued on Next Page ➤

4. If any glass seating surface is outside of the tolerance it must be restored to this flatness.
5. If it can not be restored, the entire sight window must be disposed of and replaced.
6. If within the 0.005" tolerance, proceed to assembly of the sight window.

⚠ WARNING
Seating surface flatness outside of the 0.005" tolerance specified can cause glass breakage resulting in sudden release of contained media causing serious injury to personnel.

Assembly

1. Install one cushion into the cover flange.
2. Install glass centered inside cover.
3. Install shield (if any) onto glass, then gasket being careful to keep components centered.
4. Install cover to chamber maintaining components aligned inside.
5. Install bolts and nuts as required. Using a torque wrench, tighten nuts in 3 foot-pound increments following the sequence shown in **Figure 1**.

Bolt torque is vital to proper operation of a sight window. Gaskets compress over a period of time; therefore, bolt torque must be checked on a regular basis and brought up to those recommended in the chart below.

Torque		
Unit Size	Gasket Material	
	Neoprene, Buna, Viton®	Teflon®, Graphite & Non-Asbestos
1"	3 - 5 ft-lbs	3 - 5 ft-lbs
1-1/2"	5 - 7 ft-lbs	7 - 10 ft-lbs
2"	9 - 11 ft-lbs	14 - 16 ft-lbs
3"	17 - 21 ft-lbs	31 - 35 ft-lbs
4"	11 - 15 ft-lbs	19 - 23 ft-lbs
6"	30 - 34 ft-lbs	46 - 50 ft-lbs
8"	37 - 41 ft-lbs	48 - 52 ft-lbs

**Figure 1
Bolt Torquing Sequence**

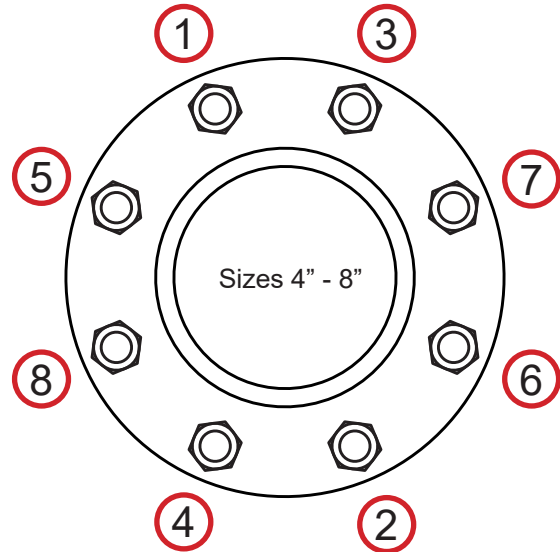
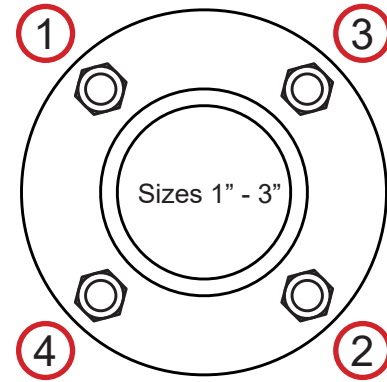

IV. OPERATION

Pre-Operational Check

1. Check that all installation procedures have been completed.
2. Check that bolts have been torqued to their proper values stated in **Section III Installation** above.
3. Check that glass is clean and free of any damage as described with **Section III Installation** above.
4. Check to determine that all connections are pressure tight.

Operating

⚠ WARNING
Sight window installations must be brought into service slowly to avoid excessive shock or stress on the glass. Rapid pressurization of the sight window can cause glass to break resulting in a sudden release of pressure, causing serious personnel injury.

V. MAINTENANCE

Use only experienced personnel who are familiar with this equipment and that thoroughly understood all the instructions in this manual for all maintenance.

⚠ WARNING

Do NOT proceed with any maintenance unless the sight window has been relieved of all pressure or vacuum, has been allowed to reach ambient temperature, and has been drained or purged of all media. Failure to do so can cause serious injury to personnel.

On all installations, regularly check the following items for purposes of maintenance.

- Glass, for cleanliness and signs of damage or wear.
- Shields, if used, for signs of clouding, wear, or deterioration.
- Sight window, for signs of leakage at gaskets or at connections.
- Sight window, for signs of internal or external corrosion.
- Bolt torque values.

The user must create maintenance schedules, safety manuals and inspection details for each specific installation of a sight window. They must determine upon evaluation of their own operating experience an appropriate maintenance schedule necessary for the specific application. Realistic maintenance schedules can only be determined with full knowledge of the services and application situation involved.

General Maintenance Procedures

Glass

⚠ WARNING

Regular and careful attention must be given to the cleaning and inspection of glass. Glass that is etched or scratched is weakened and may break under pressure. Design ratings are no longer valid for sight windows with weakened or damaged glass. Failure to replace damaged glass can cause serious personal injury to personnel.

Cleaning - Keep glass clean using a commercial glass cleaner and soft cloth. Do NOT use wire brushes, metal scraper, or an device which could scratch the glass.

Inspection - Inspect the glass surface for any signs of clouding, etching, scratches or other damage. Shining a light at a ~45° angle will aid in detecting any imperfections. Detection of such issues or any surface wear is sufficient evidence of damage. Immediately take the sight window out of service. Do NOT proceed with operation of the sight window until the shields, gaskets and glass have been replaced.

Shields

Inspection - Shields which show clouding, wear or deterioration are an indication that the sight window has been exposed or soon to be exposed to the contained media. Detection of such, should result in the sight window to be removed from service immediately. Do NOT proceed with operation of the sight window until the shields, gaskets and glass have been replaced.

Gasket Leaks

Any detection of gasket leaks must be immediately repaired, taking the sight window out of service. Do NOT proceed with operation of the sight window until the shields, gaskets and glass have been replaced.

Corrosion

It is the user's responsibility to choose materials of construction compatible with both the contained fluid and surrounding atmosphere in the user's specific application. If any corrosion is present, an investigation must immediately be carried out by the user as to the cause of the problem, including consulting with John C Ernst LLC.

Bolt Torque

Bolt Torquing Schedules should be developed by checking values daily until an appropriate cycle becomes apparent. The appropriate schedule is such that the minimum torque is always maintained while not exceeding maximums at any time shown on **Page 3**.

Disassembly

1. Loosen the bolts and/or nuts and remove.
2. Remove cover.
3. Discard glass gaskets cushions and shields.

⚠ WARNING

Do NOT under any circumstances reuse glass, gaskets, cushions and shields since they may cause high stress points resulting in glass breakage. If reused, this can result in serious personal injury to personnel.

Reassembly

1. Refer to the exploded view under the Spare Parts Index.
2. Prepare for installation of new glass by first cleaning the cushion seating surface on the cover and the gasket seating surface on the chamber. Use a soft metal (brass) scrapper to remove all burrs, rust and remnants of old cushion or gasket which may be present. Exercise caution to avoid gouging or scarring the surfaces.
3. Upon receipt of glass, inspect each piece individually for shipping damage. During inspection, and during any subsequent handling. Keep glass from contacting each other or any other surfaces including tabletops. If damage is evident or suspected do not use the glass.

Continued on Next Page ➤

Glass should be kept in original wrap within original box until ready to use.

⚠ WARNING

Bumping or sliding of glass against each other or against other surfaces may result in glass breaking, scratching, or chipping. Glass that is broken is dangerous and useless. It must be disposed of. Use of such glass can cause serious injury to personnel.

4. Assemble the components as shown in the exploded view in the **Spare Parts Index**.
5. Thread must be clear of paint, rust, and scale to achieve proper torque. Use of a light coat of oil may be applied, then tighten them finger tight.
6. Use a torque wrench to tighten the bolts and/or nuts. Use the torque sequence in Figure 1 to tighten in increments of 3 ft-lbs until the specified max torque is achieved for the specific size sight window as shown in the chart on **Page 3**.
7. Gaskets will become compressed a short time after the bolts/nuts are tightened and the torque will relax. The sight window must be re-torqued after 24 hours in service.

⚠ WARNING

Do NOT re-torque a sight window while under pressure or vacuum. It must be freed of all pressure or vacuum, allowed to reach ambient temperature and drained or purged of all media before re-torquing is performed. Failure to follow this procedure can result in serious personal injury to personnel.

8. Refer to **Section IV. Operation**, when returning the sight window to service.

Troubleshooting

Problem: *Glass or shield becomes etched or clouded.*

Potential Solution:

- Install shields that are unaffected by media. This can be due to the process media interacting with a non-compatible glass or shield.

Problem: *Glass continually breaks in service.*

Potential Solution:

- Replace sight window. The chamber has been wrapped as a result of thermal stresses.

VI. SPARE PARTS INDEX

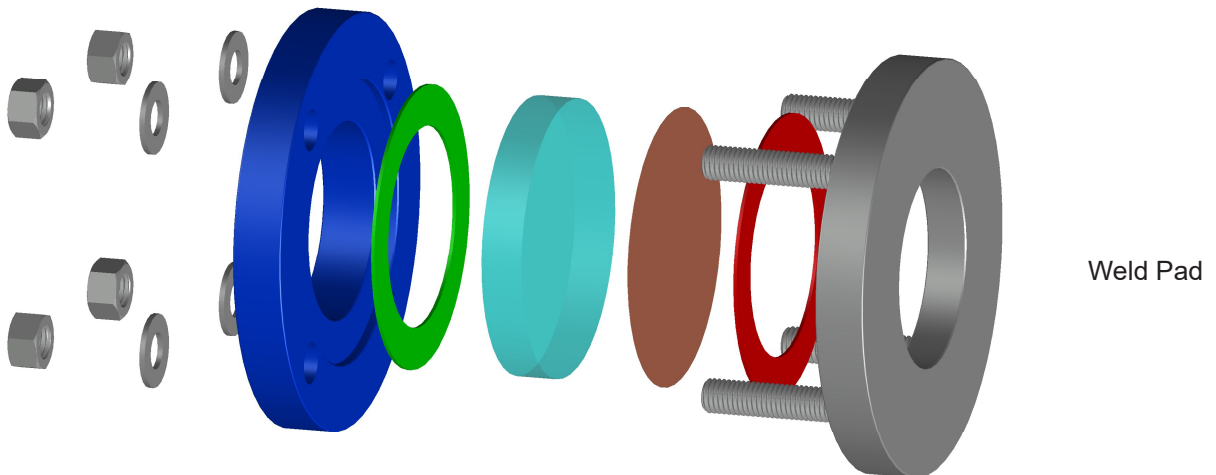
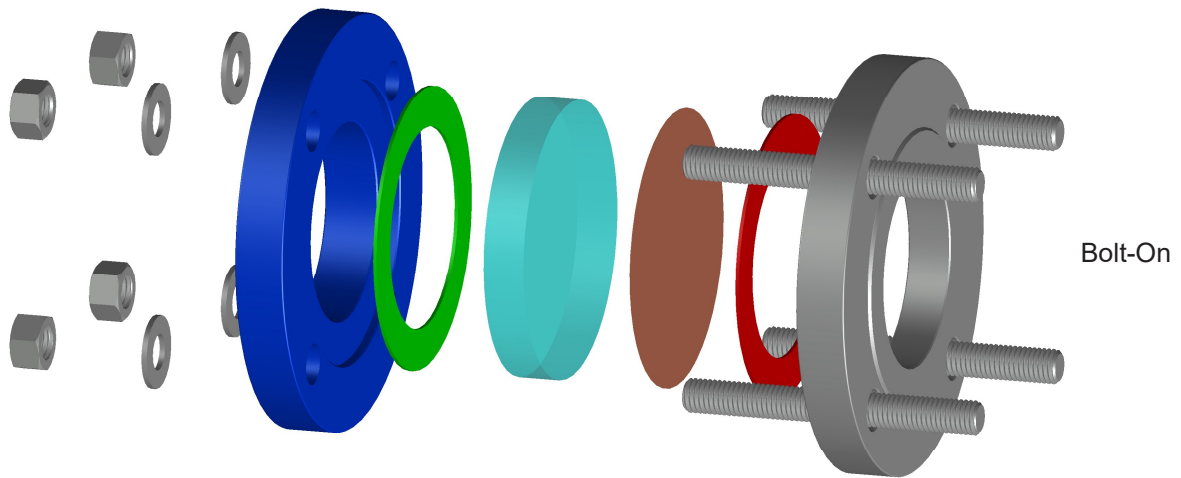
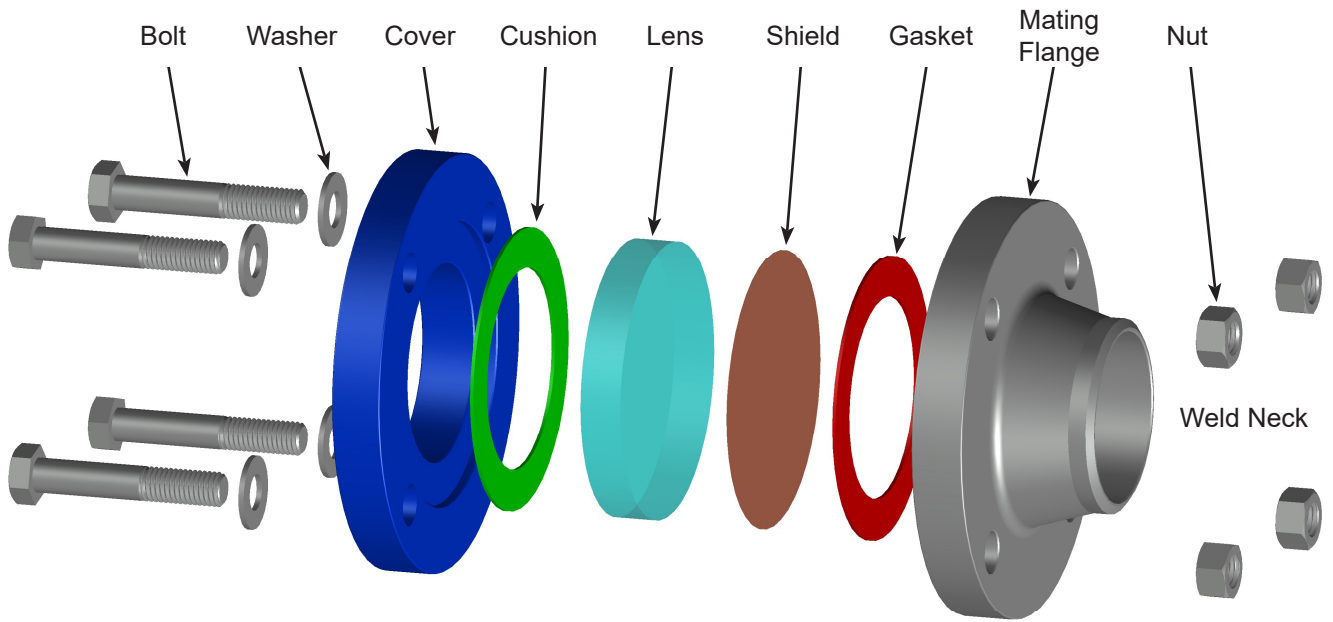

LIMITED WARRANTY

Period of Coverage

The John C. Ernst LLC. expressly warrants products to the original purchaser to be free from defects in the material and workmanship for 12 months from date of shipment. John C. Ernst LLC. will, at its option, replace or repair any products which fail during the warranty period due to defective material or workmanship. Evaluations, repairs, and replacements will most often occur in Sparta NJ 07871 USA, or another facility determined by the John C. Ernst LLC.. The warranty does not cover costs required to transport warranted units to or from the John C. Ernst facility.

Limitations

The responsibility of the John C. Ernst LLC. is hereunder limited to repairing or replacing the product at its expense. This warranty shall not apply if the product has been disassembled, tampered with, repaired, subjected to misuse, neglect, accident, or otherwise altered in any way. The warranty does not guarantee products against normal wear, glass breakage, clouding, or corrosion. The John C. Ernst LLC. shall not be liable for loss, shipping costs, damage, or expenses related directly or indirectly to the installation or use of its products. It is expressly understood that the John C. Ernst LLC. is not responsible for damage or injury caused to other products, buildings, personnel, citizens, or property by reason of the installation or use of its products.

Advertised ratings apply only to units serviced with parts supplied by the John C. Ernst LLC. Service must be done in accordance with the instructions of the product that is being serviced.

THIS IS JOHN C. ERNST, CO's. SOLE WARRANTY AND IN LIEU OF ALL OTHER WARRANTIES, EXPRESSED OR IMPLIED WHICH ARE HEREBY EXCLUDED, INCLUDING IN PARTICULAR ALL WARRANTIES OF MERCHANTABILITY OR FITNESS FOR A PARTICULAR PURPOSE. WE WILL NOT BE LIABLE FOR INCIDENTAL, CONSEQUENTIAL OR SPECIAL DAMAGES OF ANY NATURE.

How to get Warranty Service

Prior to submitting any claim for warranty service, the owner must submit proof of purchase, and obtain written authorization to return the product. All returns must be sent back with an MSDS for the application that the product was used in, and with a maintenance log of all service including inspections. Thereafter, the product shall be returned to the John C. Ernst LLC. with freight paid and packaged to prevent damage in transit. Should damage in transit occur the John C. Ernst LLC. will not be held liable.

GENERAL PRESERVATION

Recommended Practice for Long Term Storage of John C. Ernst Products

1. All units should be inspected upon receipt to ensure that no damage has been incurred during transit. If there has been damage, a claim should be filed with the carrier immediately. Units should be stored in an area protected from the elements and corrosive fumes, in a secure manner where they can neither fall nor be struck by other objects. Care should be taken to protect the glass and the end connections from damage. Avoid placing any objects directly on the glass(es) at any time.
2. Units should be checked to ensure that they contain no foreign matter and that the end connections are clean, undamaged, and in line with adjoining piping. Examine each glass carefully using a flashlight for any indications of chips, scratches, blemishes or cloudiness. Inspect for scratches, shining a bright concentrated light (powerful flashlight will suffice) at about a 45° angle. Any scratch that glistens and catches a fingernail, or star or crescent-shaped mark that glistens, is cause for replacement. Process surface that appears cloudy or roughened, after cleaning, is evidence of chemical attack and is cause for replacement. If any type of flaw is apparent, the unit should not be installed until the glass and gaskets have been replaced. Follow the torquing recommendations given by the gasket and piping manufacturers to achieve proper sealing pressures.
3. Some products are shipped unassembled, as they are to be welded into position and then assembled. Individual pieces should be carefully stored in a manner to avoid damage until installation. The glass requires special attention. It should not be stored or mixed with objects that may cause damage and should remain wrapped or boxed until assembly.
4. Gaskets frequently assume a compression-set over a period of time. Some materials, however, may compress/relieve or creep. Visually inspect the gaskets for gaps or looseness before start-up. If the gaskets are not compressed, adjust the unit gasket compression. Do not tighten any fasteners or clamps while the unit is in operation.
5. Periodic visual inspection should be made to ensure that no leaks are evident and that there is no clouding, scratching, or blemishing of the glass. Keep glasses clean using commercial glass cleaners. Cleaning should be done without removing glass. This may require recirculation of cleaning material if process side of glass is not accessible. Never use harsh abrasives, wire brushes, metal scrapers, or anything that may scratch the glass. Do not attempt to clean glasses while equipment is in operation.
6. Should leaking around the glass occur, first check the glass for damage. If the glass appears to be in good condition, the gasket seal should be checked, but only after the system pressure has been brought down to zero. If the gasket appears to be loose, or hardly compressed, the spacers must be adjusted. If the leak persists after repressurizing, disassemble and replace the gaskets.
7. Glass, shields and gaskets that have been removed, **MUST BE REPLACED**. Used parts may contain hidden damage. Induced stress in glass and de-tempering are **NOT** visible to the naked eye. Be sure that the replacement glass is proper for the service.
8. Inspect protective coating (if applied) for chipping.
9. Store within the temperature extremes of the nameplate or specification documents – do not expose to direct sunlight or other UV sources.
10. Products should be stored off of the floor on suitable skids, pallets, or racks and protected from dirt, debris, and exposure to direct sunlight, particularly to soft sealing surfaces.
11. Store in a cool dry place, room temperatures between 40°F - 80°F with a relative humidity level between 40 – 75%.
12. Store in dry areas, avoiding any contamination with any liquids. Products should be kept in a clean, heated, weather-tight (dry), well ventilated facility.
13. If a flanged product is to be stored for any extended period of time, the flange or end protector should be examined to ensure they are fastened securely, and any other open areas should be sealed to prevent any moisture damage.
14. Product assemblies with electrical components, pneumatic tubing, positioners, actuators, and other accessories should be protected from impact.
15. Useful Life When Stored:
 - a. Unit: Indefinite, based on ideal storage conditions.
 - b. Spare Gaskets: Indefinite, based on ideal storage conditions.
 - c. After 9 months, the torque of the bolting should be checked as the gasket relaxes. This should be done for units not in service as well as those installed in process.
 - d. The useful life of the material, when the storage conditions differ from the recommended factors is not known. It has been established, however, that room temperature has a significant influence on the shelf life of material.
 - e. Spare Gaskets should be stored flat.
16. Periodical checks at least every 6 months have to be carried out in the storage area to verify that the above mentioned conditions are maintained.

If there are any questions or concerns, please contact the John C. Ernst LLC. Sales Office at 888-943-5000.

Teflon® & Viton® are Registered Trademarks of the Chemours Company

